

KS54AHCT 240/241/244 Octal Buffers and Line Drivers KS74AHCT with 3-State Outputs

T-52-07

FEATURES

- Function, pin-out, speed and drive compatibility with 54/74ALS logic family
- Low power consumption characteristic of CMOS
- 3-State outputs with drive current ($I_{OL} = 24 \text{ mA} @ V_{OL} = 0.5V$) for direct bus interface
- Inputs and outputs interface directly with TTL, NMOS and CMOS devices
- Wide operating voltage range: 4.5V to 5.5V
- Characterized for operation over industrial and military temperature ranges:
KS74AHCT: -40°C to $+85^{\circ}\text{C}$
KS54AHCT: -55°C to $+125^{\circ}\text{C}$
- Package options include plastic "small outline" packages, standard plastic and ceramic 300-mil DIPs

DESCRIPTION

These high-speed octal buffers and line drivers are designed specifically to improve both the performance and density of 3-state memory address drivers, clock drivers, and bus-oriented receivers and transmitters.

The designer has the choice of combinations of inverting/non-inverting outputs and symmetrical complementary input control (both active-low, or one active-low, the other active-high).

These devices provide speeds and drive capability equivalent to their ALSTTL counterparts and yet maintain CMOS power levels. The input and output voltage levels allow direct interface with TTL, NMOS and CMOS devices without any external components.

All inputs and outputs are protected from damage due to static discharge by internal diode clamps to V_{CC} and ground.

PIN CONFIGURATION

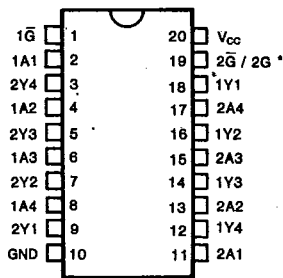

*2G for '240 and '244
2G for '241

LOGIC DIAGRAMS

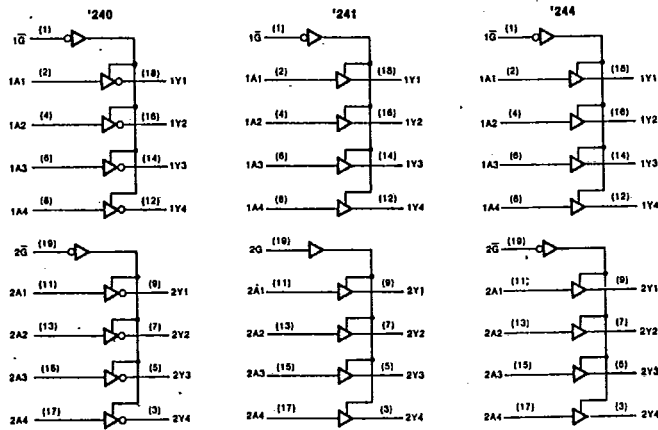

FUNCTION TABLE

Input			'241, '244	'240
			Output	Output
G	\bar{G}	A	Y	Y
H	L	L	L	H
H	L	H	H	L
L	H	X	Z	Z

KS54AHCT 240/241/244 Octal Buffers and Line Drivers
KS74AHCT with 3-State Outputs

T-52-07

Absolute Maximum Ratings*

Supply Voltage Range V_{CC} -0.5V to +7V
 DC Input Diode Current, I_{IK}
 ($V_I < -0.5V$ or $V_I > V_{CC} + 0.5V$) ± 20 mA
 DC Output Diode Current, I_{OK}
 ($V_O < -0.5V$ or $V_O > V_{CC} + 0.5V$) ± 20 mA
 Continuous Output Current Per Pin, I_O
 ($-0.5V < V_O < V_{CC} + 0.5V$) ± 70 mA
 Continuous Current Through
 V_{CC} or GND pins ± 250 mA
 Storage Temperature Range, T_{stg} ... -65°C to +150°C
 Power Dissipation Per Package, P_d † 500 mW

* Absolute Maximum Ratings are those values beyond which permanent damage to the device may occur. These are stress ratings only and functional operation of the device at or beyond them is not implied. Long exposure to these conditions may affect device reliability.

† Power Dissipation temperature derating:
 Plastic Package (N): -12mW/°C from 65°C to 85°C
 Ceramic Package (J): -12mW/°C from 100°C to 125°C

Recommended Operating Conditions

Supply Voltage, V_{CC} 4.5V to 5.5V
 DC Input & Output Voltages*, V_{IN} , V_{OUT} .. 0V to V_{CC}
 Operating Temperature

Range KS74AHCT: -40°C to +85°C
 KS54AHCT: -55°C to +125°C

Input Rise & Fall Times, t_r , t_f Max 500 ns

* Unused inputs must always be tied to an appropriate logic voltage level (either V_{CC} or GND)

DC ELECTRICAL CHARACTERISTICS ($V_{CC}=5V \pm 10\%$ Unless Otherwise Specified)

Characteristic	Symbol	Test Conditions	$T_a = 25^\circ\text{C}$			Unit	
			Typ	KS74AHCT $T_a = -40^\circ\text{C to } +85^\circ\text{C}$	KS54AHCT $T_a = -55^\circ\text{C to } +125^\circ\text{C}$		
Minimum High-Level Input Voltage	V_{IH}			2.0	2.0	2.0	V
Maximum Low-Level Input Voltage	V_{IL}			0.8	0.8	0.8	V
Minimum High-Level Output Voltage	V_{OH}	$V_{IN}=V_{IH}$ or V_{IL} $I_O=-20\mu\text{A}$ $I_O=-6\text{mA}$	V_{CC} 4.2	$V_{CC}-0.1$ 3.98	$V_{CC}-0.1$ 3.84	$V_{CC}-0.1$ 3.7	V
Maximum Low-Level Output Voltage	V_{OL}	$V_{IN}=V_{IH}$ or V_{IL} $I_O=20\mu\text{A}$ $I_O=12\text{mA}$ $I_O=24\text{mA}$	0	0.1 0.26 0.39	0.1 0.33 0.5	0.1 0.4	V
Maximum Input Current	I_{IN}	$V_{IN}=V_{CC}$ or GND		± 0.1	± 1.0	± 1.0	μA
Maximum 3-State Leakage Current	I_{OZ}	Output Enable = V_{IH} $V_{OUT}=V_{CC}$ or GND		± 0.5	± 5.0	± 10.0	μA
Maximum Quiescent Supply Current	I_{CC}	$V_{IN}=V_{CC}$ or GND $I_{OUT}=0\mu\text{A}$		8.0	80.0	160.0	μA

KS54AHCT 240/241/244 Octal Buffers and Line Drivers
KS74AHCT with 3-State Outputs T-52-07
AC ELECTRICAL CHARACTERISTICS (Input $t_r, t_f \leq 2$ ns), AHCT240, AHCT241, AHCT244

Characteristic	Symbol	Conditions†	$T_a = 25^\circ\text{C}$	KS74AHCT		KS54AHCT		Unit	
			$V_{CC} = 5.0\text{V}$	$T_a = -40^\circ\text{C to } +85^\circ\text{C}$		$T_a = -55^\circ\text{C to } +125^\circ\text{C}$			
			Typ	Min	Max	Min	Max		
Propagation Delay, A to Y	t_{PLH}	$C_L = 50\text{pF}$	6		10		12	ns	
		$C_L = 150\text{pF}$	9		15		18		
	t_{PHL}	$C_L = 50\text{pF}$	6		10		12		
		$C_L = 150\text{pF}$	9		15		18		
Output Enable Time, Enable to Y	t_{PZH}	$R_L = 1\text{k}\Omega$	$C_L = 50\text{pF}$	12		20		24	ns
			$C_L = 150\text{pF}$	15		25		30	
	t_{PZL}	$C_L = 50\text{pF}$	$C_L = 50\text{pF}$	12		20		24	
			$C_L = 150\text{pF}$	15		25		30	
Output Disable Time, Enable to Y	t_{PHZ}	$R_L = 1\text{k}\Omega$	13		18		22	ns	
	t_{PLZ}	$C_L = 50\text{pF}$	13		18		22		
Input Capacitance	C_{IN}		5					pF	
Output Capacitance	C_{OUT}	Output Disabled	10					pF	
Power Dissipation Capacitance*	C_{PD}	Output Disabled	5					pF	
		Output Enabled	30						

* C_{PD} determines the no-load dynamic power dissipation: $P_D = C_{PD} V_{CC}^2 f + I_{CC} V_{CC}$.

† For AC switching test circuits and timing waveforms see section 2.

PACKAGE DIMENSIONS

T-90-20

1. PLASTIC PACKAGES

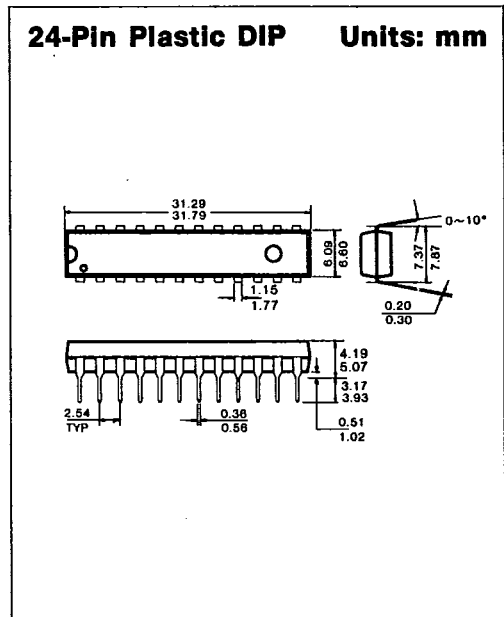
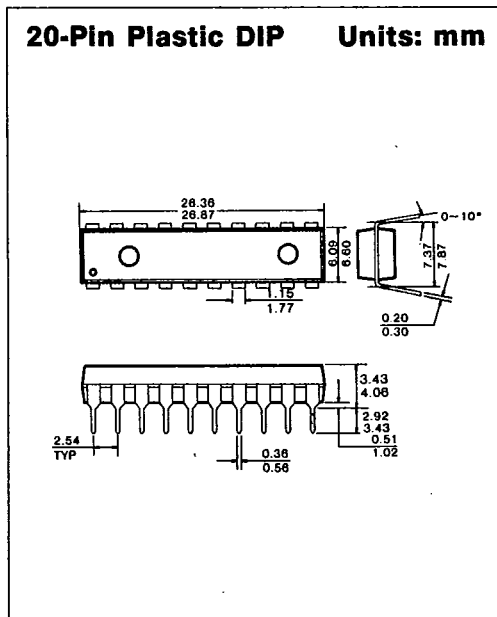
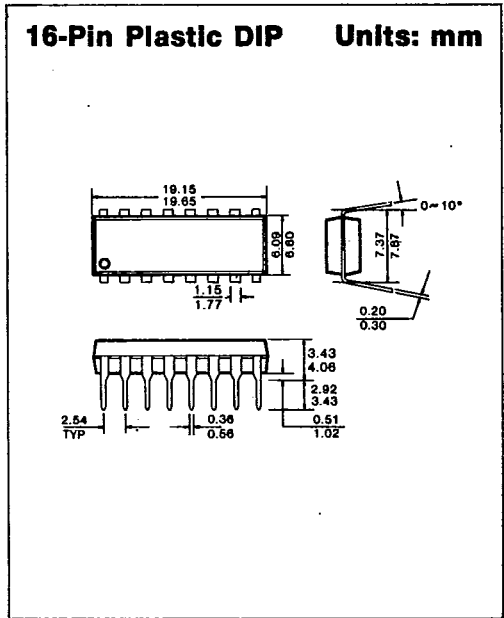
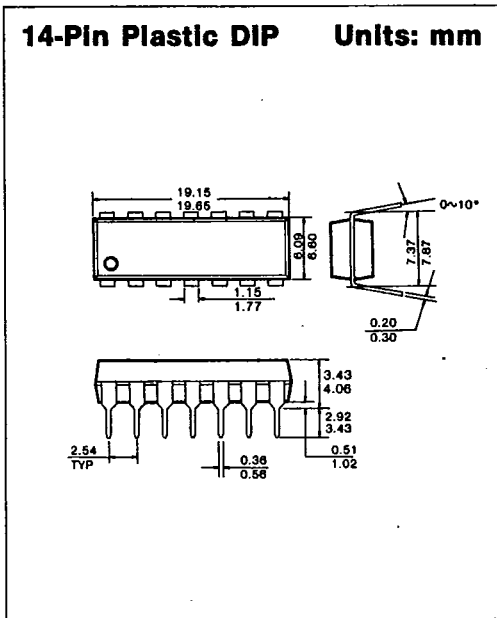

7



SAMSUNG SEMICONDUCTOR

1675

A-04

PACKAGE DIMENSIONS

T-90-20

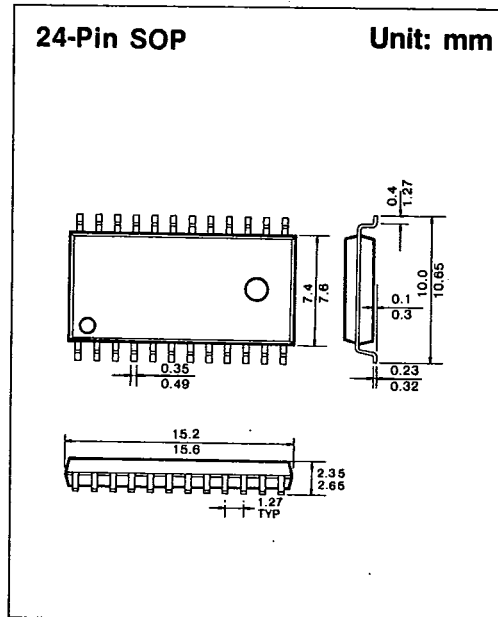
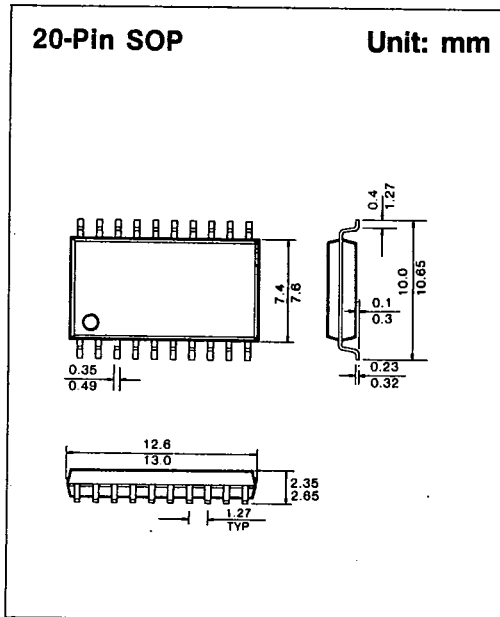
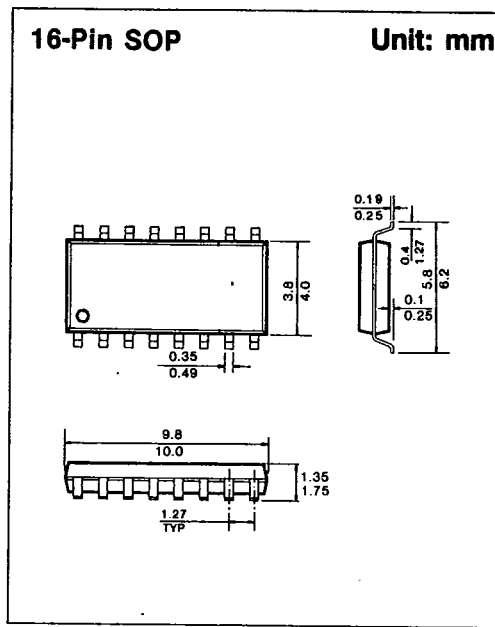
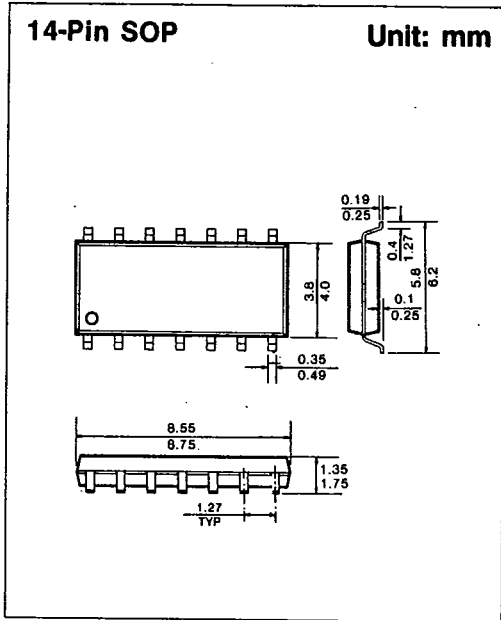

PACKAGE DIMENSIONS

T-90-20

2. CERAMIC PACKAGES

14-Pin Ceramic DIP Units: mm

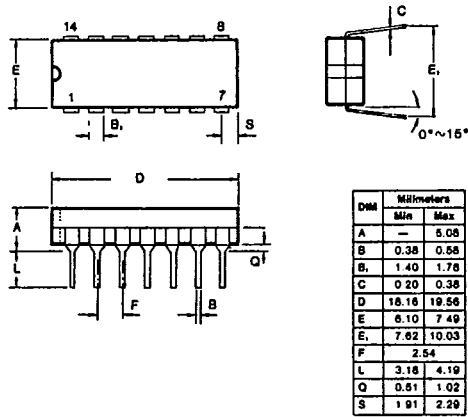

16-Pin Ceramic DIP Units: mm

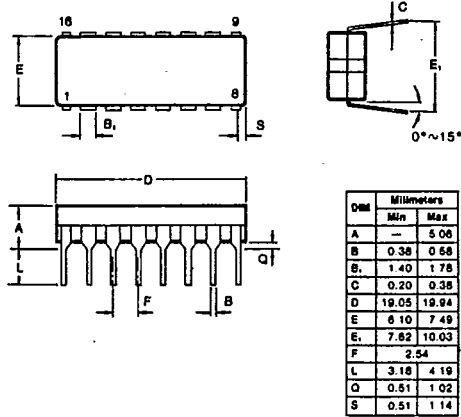

20-Pin Ceramic DIP Units: mm

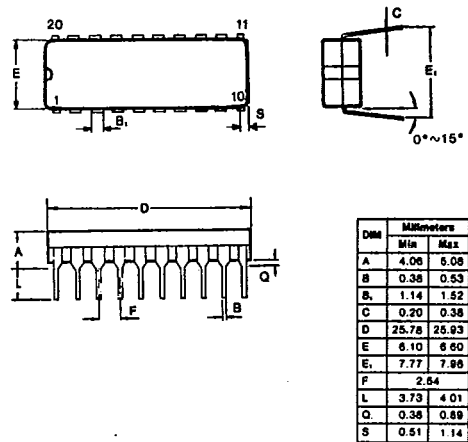

24-Pin Ceramic DIP Units: mm

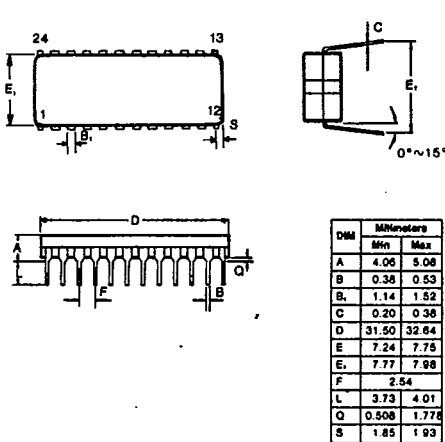

7